



M3-M12 Electric Tapping Arm

Part No: TA-EL-3-12
Doc V: 1.1



Table sold separately

- Tapping range M3 to M12 with 1000mm working reach.
- Simple push button forward and reverse operation with LCD display menu system for setting RPM and thread pitch to program auto reverse.
- Vertical and Horizontal adjustable tapping head.
- Low Maintenance.
- Reduce tap breakage and remove tapping operations from machine tools.
- Blind and through hole tapping.
- Collet set included.
- Easy to re-align with threaded holes to remove contamination after painting or coating processes.

Specifications

Specifications	
Tapping capacity	M3 to M12 (in mild steel)
Maximum working range	1000mm radius
Head operating position	Adjustable vertical or horizontal
Collet type	"Bliz" Type (19mm diameter)
Motor type	Brushless servo
Revolutions per minute (RPM)	375 rpm
Voltage	220v
Motor power	600W
Current rating	10A
Weight	21 Kg



Controls

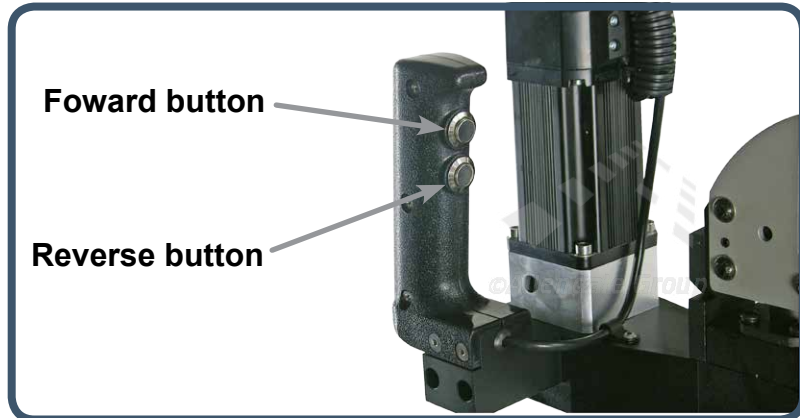

Manual: Simple push button forward and reverse operation.

Automatic: Set thread pitch and depth of thread, for auto reverse.

Configuration: Set forward and reverse motor speed.

Default: Restore default setting.

Working Area

The tapping arm has a working area of 200mm from its base and 1000mm overall reach and can rotate 360° around its mounting base. The long reach of the tapping arm allows large fabrications or multiple components to be tapped without the need for re-locating. There is also less need for jigs or holding fixtures to locate the work piece, as the tap can be easily aligned with the drilled hole as required.

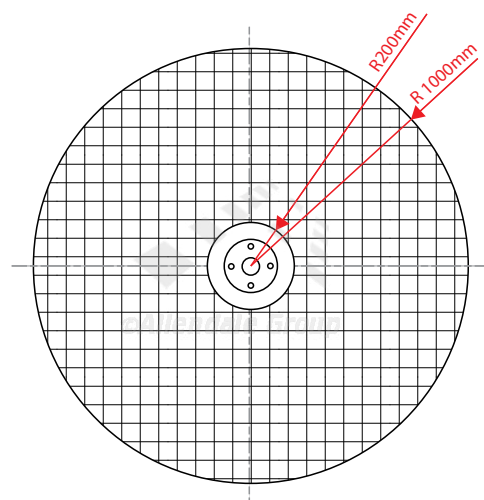



Mounting Base Dimensions

The mounting base has four 9mm diameter mounting holes, to secure the arm to a bench or a machine table.

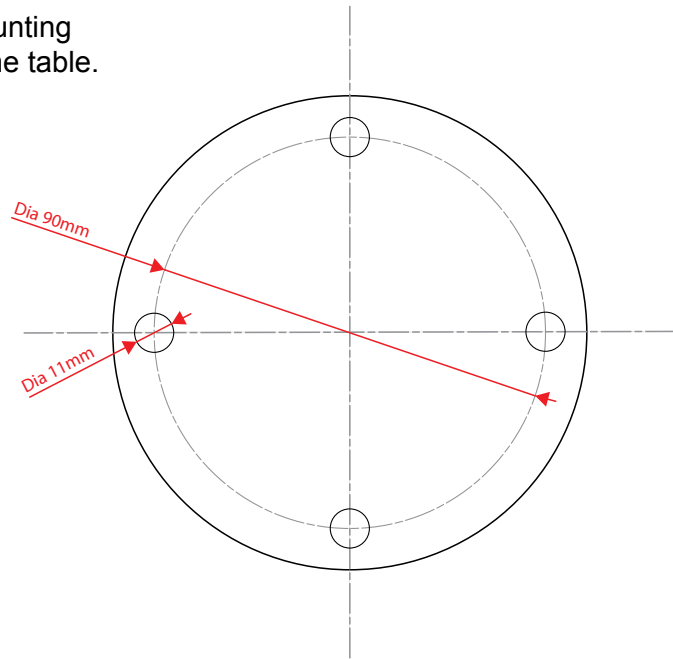
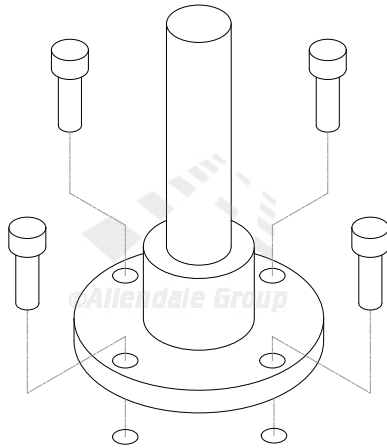

Tapping Collets Included

The machine taps are held in a quick change collet system. Each collet has a ratchet clutch to prevent tap breakage and blind hole threading. The torque is preset for each size of tapping collet, this can be adjusted if required. The quick release system allows the collet to be removed and the next collet to be inserted rapidly.

The arm is supplied complete with a set of 7 collets.

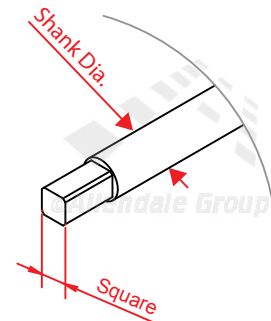

Tap Size	Tap Shank Diameter	Tap Square	Machine Tap Standard
M3	3.15mm	2.5mm	ISO 529
M4	4mm	3.15mm	ISO 529
M5	5mm	4mm	ISO 529
M6	6.3mm	5mm	ISO 529
M8	6.3mm	5mm	ISO 2283~BS949
M10	8mm	6.3mm	ISO 2283~BS949
M12	9mm	7.1mm	ISO 2283~BS949

Please note: Machine taps are not included but available separately, please visit www.machine-tapping.co.uk for more details.