

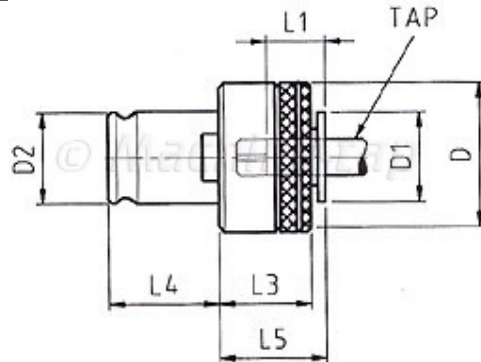

Suppliers of Tapping Equipment...

Type 2 Tap collet Technical...



| Model Number | Collet Type | Tap Dimensions | | | | All dimensions in mm | | | | | |
|---------------|-------------|----------------|-------|--------|----|----------------------|----|----|----|----|----|
| | | Size | Shank | Square | D | D1 | D2 | L1 | L3 | L4 | L5 |
| ARM-M5-TYPE2 | TYPE 2 | M5 | 6 | 4.9 | 50 | 30 | 31 | 30 | 31 | 35 | 33 |
| ARM-M6-TYPE2 | TYPE 2 | M6 | 6.3 | 5 | 50 | 30 | 31 | 30 | 31 | 35 | 33 |
| ARM-M8-TYPE2 | TYPE 2 | M8 | 8 | 6.3 | 50 | 30 | 31 | 30 | 31 | 35 | 33 |
| ARM-M10-TYPE2 | TYPE 2 | M10 | 10 | 8 | 50 | 30 | 31 | 30 | 31 | 35 | 33 |
| ARM-M12-TYPE2 | TYPE 2 | M12 | 9 | 7.1 | 50 | 30 | 31 | 30 | 31 | 35 | 33 |
| ARM-M14-TYPE2 | TYPE 2 | M14 | 11.2 | 9 | 50 | 30 | 31 | 30 | 31 | 35 | 33 |
| ARM-M16-TYPE2 | TYPE 2 | M16 | 12.5 | 10 | 50 | 30 | 31 | 30 | 31 | 35 | 33 |
| ARM-M18-TYPE2 | TYPE 2 | M18 | 14 | 11.2 | 50 | 30 | 31 | 30 | 31 | 35 | 33 |
| ARM-M20-TYPE2 | TYPE 2 | M20 | 14 | 11.2 | 50 | 30 | 31 | 30 | 31 | 35 | 33 |
| ARM-M22-TYPE2 | TYPE 2 | M22 | 16 | 12.5 | 50 | 30 | 31 | 30 | 31 | 35 | 33 |

Quick change collet chuck...



The pneumatic motor is equipped with a chuck and each tap is held in its own collet (*collets supplied separately*). To change to a different tap size, lift the locking ring on the chuck. This will eject the collet from the motor. Select the collet with the desired tap size. Insert the collet into the chuck. Locate the two drive pegs on the collet and release the locking ring to secure.

Images & Content © Allendale Electronics Limited.

E&OE - Specifications subject to change without prior notice.